

Data sheet HEATER COOLING

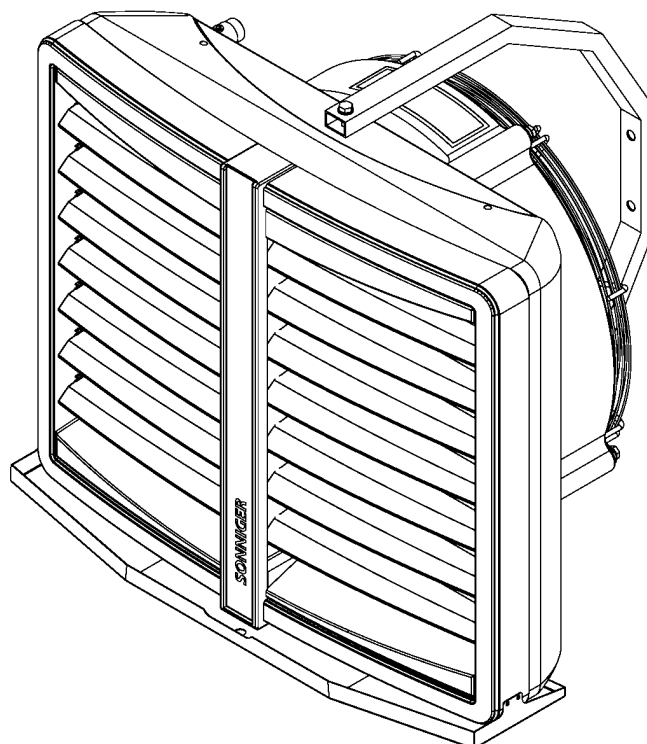

The HEATER COOLING drip tray is intended for operation of HEATER CONDENS water heaters with a cooling agent. The purpose of the tray is to collect the emerging condensate and discharge it to the stub pipe (the resulting condensate is not harmful to the environment). The tray does not include mounting elements or a condensate drain hose. Connect the condensate drain to the existing sewage system or drain it in a way that prevents water from accumulating in the tray.

Cooling parameters HEATER CONDENS

Suggested operating speed of the heater in the system with a cooling agent, gear I and II (0 to 7V for EC engines) to prevent water condensing on the exchanger from rising. In conditions of low air humidity (<30%), with limited condensation, operation in gear III is allowed (above 7V for EC engines)

		HEATER CONDENS CR 2																													
inlet/outlet water temperature		3/8					5/10					6/12					7/12					7/10					10/15				
inlet air temperature		18,00	20,00	23,00	25,00	30,00	18,00	20,00	23,00	25,00	30,00	18,00	20,00	23,00	25,00	30,00	18,00	20,00	23,00	25,00	30,00	18,00	20,00	23,00	25,00	30,00	18,00	20,00	23,00	25,00	30,00
		Airflow 3350 m³/h (speed 3)																													
Cooling power	kW	3,18	4,33	6,03	7,42	12,75	2,17	3,37	5,10	6,19	10,66	1,79	2,01	3,60	4,73	7,99	1,57	2,36	4,11	5,24	8,73	3,22	4,37	6,05	7,34	12,84	1,03	1,39	2,58	3,72	6,56
Outlet air temp	°C	15,20	16,10	17,60	18,90	22,50	16,10	17,00	18,40	19,40	22,90	16,40	18,20	19,80	20,70	23,60	16,60	17,90	19,30	20,20	23,30	15,20	16,10	17,50	18,90	22,50	17,10	18,80	20,70	21,60	24,00
water flow	m³/h	0,54	0,74	1,02	1,27	2,17	0,37	0,58	0,88	1,05	1,83	0,26	0,29	0,52	0,67	1,15	0,27	0,41	0,71	0,90	1,49	0,91	1,25	1,73	2,08	3,63	0,18	0,24	0,44	0,64	1,13
pressure drop	kPa	4,62	7,87	14,02	20,24	51,06	2,34	5,05	10,49	14,23	37,07	1,21	1,49	4,08	6,48	16,28	1,33	2,69	7,06	10,72	25,34	10,86	18,85	33,31	45,41	119,48	0,62	1,06	3,00	5,64	15,04
		Airflow 2000 m³/h (speed 2)																													
Cooling power	kW	2,31	3,15	4,41	5,46	9,60	1,73	2,44	3,65	4,53	8,07	1,62	1,88	2,59	3,42	5,95	1,49	1,72	2,95	3,75	6,56	2,33	3,15	4,36	5,47	9,67	1,34	1,87	2,70	4,70	4,81
Outlet air temp	°C	14,60	15,30	16,60	17,90	21,00	15,40	16,40	17,50	18,40	21,00	15,60	17,20	19,10	19,80	22,50	15,80	17,40	18,60	19,30	22,20	14,60	15,30	16,60	17,80	20,90	18,00	20,20	20,90	22,00	24,00
water flow	m³/h	0,39	0,54	0,76	0,93	1,64	0,30	0,42	0,63	0,78	1,39	0,23	0,27	0,37	0,49	0,86	0,26	0,30	0,50	0,64	1,13	0,66	0,91	1,25	1,59	2,76	0,23	0,32	0,47	0,83	0,83
pressure drop	kPa	2,68	4,62	8,32	11,81	31,31	1,60	2,90	5,80	8,57	23,11	1,03	1,32	2,30	3,76	9,81	1,22	1,56	3,90	5,85	15,59	6,32	10,86	18,85	28,61	74,17	0,97	1,73	3,30	6,94	8,94
		Airflow 1450 m³/h (speed 1)																													
Cooling power	kW	1,89	2,52	3,57	4,47	7,92	1,65	1,95	2,94	3,68	6,68	1,45	1,78	2,08	2,75	4,88	1,41	1,60	2,37	3,02	5,41	1,88	2,52	3,51	4,47	7,97	1,21	1,52	2,16	3,89	3,89
Outlet air temp	°C	14,10	14,80	16,00	17,20	20,00	14,60	16,00	16,90	17,80	20,80	15,00	16,30	18,70	19,20	21,80	15,10	16,70	18,10	18,70	21,50	14,20	14,80	16,00	17,20	19,90	17,50	19,80	20,50	22,40	24,00
water flow	m³/h	0,32	0,43	0,61	0,76	1,34	0,28	0,33	0,50	0,64	1,15	0,21	0,26	0,30	0,39	0,70	0,24	0,27	0,41	0,52	0,93	0,54	0,71	1,00	1,30	2,27	0,21	0,26	0,37	0,66	0,66
pressure drop	kPa	1,88	3,12	5,75	8,32	22,29	1,46	1,96	3,99	6,00	16,59	0,83	1,21	1,57	2,57	6,89	1,10	1,35	2,69	4,06	11,23	4,45	7,15	12,95	20,14	53,03	0,82	1,22	2,20	6,02	6,02
		HEATER CONDENS CR 3																													
inlet/outlet water temperature		3/8					5/10					6/12					7/12					7/10					10/15				
inlet air temperature		18,00	20,00	23,00	25,00	30,00	18,00	20,00	23,00	25,00	30,00	18,00	20,00	23,00	25,00	30,00	18,00	20,00	23,00	25,00	30,00	18,00	20,00	23,00	25,00	30,00	18,00	20,00	23,00	25,00	30,00
		Airflow 2950 m³/h (speed 3)																													
Cooling power	kW	5,49	7,00	9,73	12,15	20,10	4,12	5,65	7,99	9,99	17,24	2,41	3,82	6,14	7,64	13,50	2,69	4,28	6,53	8,10	14,30	4,98	6,44	8,89	11,18	19,10	1,61	2,14	4,48	5,99	10,47
Outlet air temp	°C	12,50	12,90	14,40	15,40	17,70	13,90	14,30	15,20	16,20	18,70	15,60	16,10	16,70	17,30	19,80	15,30	15,70	16,30	17,00	19,60	13,00	13,50	14,60	15,70	18,10	16,40	17,80	18,40	18,80	20,80
water flow	m³/h	0,94	1,20	1,67	2,08	3,46	0,71	0,97	1,38	1,73	2,96	0,36	0,55	0,88	1,08	1,93	0,46	0,74	1,12	1,38	2,43	1,44	1,85	2,55	3,19	5,53	0,28	0,37	0,77	1,03	1,79
pressure drop	kPa	4,31	9,85	31,10	45,39	107,31	6,86	11,85	21,76	32,18	81,22	1,95	4,31	9,88	14,16	38,32	3,17	7,18	14,73	21,23	56,51	23,09	35,58	62,03	91,48	236,26	1,27	2,12	7,41	10,34	32,08
		Airflow 1700 m³/h (speed 2)																													
Cooling power	kW	3,70	4,73	6,70	8,46	14,10	2,78	3,80	5,45	6,90	12,13	2,21	2,59	4,13	5,23	9,48	1,95	2,90	4,39	5,55	10,10	3,35	4,31	6,08	7,79	13,28	1,34	1,75	3,03	4,03	7,32
Outlet air temp	°C	11,50	11,90	13,20	13,90	15,50	13,20	13,30	14,10	15,00	16,80	14,10	15,40	15,70	16,20	18,80	14,60	14,90	15,20	15,90	18,00	12,20	12,40	13,50	14,40	16,10	15,70	16,90	17,60	18,00	19,60
water flow	m³/h	0,63	0,81	1,15	1,44	2,43	0,47	0,65	0,94	1,17	2,08	0,30	0,37	0,59	0,75	1,35	0,34	0,50	0,75	0,96	1,73	0,97	1,23	1,73	2,26	3,78	0,20	0,28	0,40	0,52	0,89
pressure drop	kPa	5,83	8,89	16,19	23,98	59,39	3,43	5,91	11,24	16,49	44,26	1,66	2,21	4,93	7,48	20,59	1,87	3,71	7,43	11,26	31,40	11,71	17,71	31,78	50,27	122,90	0,92	1,45	3,76	6,23	17,58
		Airflow 1200 m³/h (speed 1)																													
Cooling power	kW	2,85	3,63	5,27	6,65	11,02	2,15	2,93	4,20	5,36	9,49	2,03	2,31	3,18	4,04	7,48	1,83	2,23	3,37	4,30	7,97	2,56	3,28	4,72	6,06	10,35	1,15	1,63	2,33	3,09	5,72
Outlet air temp	°C	11,00	11,30	12,40	13,00	14,20	12,70	12,70	13,50	14,20	15,70	13,00	14,20	15,00	15,60	17,40	13,50	14,40	14,60	15,30	17,00	11,70	11,80	12,90	13,60	14,80	15,20	15,90	17,10	17,20	18,80
water flow	m³/h	0,49	0,62	0,91	1,15	1,91	0,37	0,50	0,72	0,90	1,61	0,29	0,24	0,46	0,58	1,07	0,31	0,39	0,58	0,74	1,38	0,74	0,94	1,35	1,73	2,96	0,20	0,28	0,40	0,53	0,98
pressure drop	kPa	3,71	5,60	10,92	16,19	38,99	2,25	3,80	7,11	10,65	28,52	1,45	1,81	3,19	4,72	13,83	1,65	2,35	4,69	7,18	21,23	7,27	11,10	20,71	31,78	80,22	0,72	1,31	2,42	3,95	11,45
		HEATER CONDENS CR MAX 2																													
inlet/outlet water temperature		3/8					0,5					6/12					7/12					7/10					10/15				
inlet air temperature		18,00	20,00	23,00	25,00	30,00	18,00	20,00	23,00	25,00	30,00	18,00	20,00	23,00	25,00	30,00	18,00	20,00	23,00	25,00	30,00	18,00	20,00	23,00	25,00	30,00	18,00	20,00	23,00	25,00	30,00
		Airflow 5700 m³/h (speed 3)																													
Cooling power	kW	5,75	7,69	10,43	12,79	21,66	4,14	5,98	8,75	10,66	18,25	2,59	3,59	6,44	8,31	12,85	2,40	4,35	7,14	10,00	14,92	5,57	7,42	10,12	12,37	21,36	1,55	2,05	4,66	6,53	11,22
Outlet air temp	°C	15,00	16,00	17,60	19,00	22,60	15,80	16,90	18,40	19,40	23,10	16,70	18,10	19,60	20,60	23,10	16,80	17,70	19,20	20,20	23,50	15,10	16,10	17,60	19,00	22,70	17,20	18,80	20,50	21,10	24,10
water flow	m³/h	0,99	1,29	1,80	2,20	3,69	0,72	1,02	1,49	1,83	3,15	0,37	0,51	0,92	1,19	2,13	0,41	0,75	1,22	1,53	2,64	1,60	2,20	2,88	3,56	6,17	0,27	0,35	0,80	1,12	1,93
pressure drop	kPa	5,89	15,26	27,03	38,41	93,57	5,39	9,93	19,17	27,27	69,53	1,71	2,98	8,15	12,72	26,81	2,03	5,70	13,27	19,48	46,92	21,23	35,15	58,87	84,72	216,59	0,93	1,50	6,18	11,06	26,90
		Airflow 3900 m³/h (speed 2)																													
Cooling power	kW	4,56	6,00	8,31	10,30	17,69	3,27	4,76	6,93	8,51	14,90	2,48	2,87	5,12	6,57	10,16	2,22	3,41	5,65	7,11	12,16	4,40	5,84	8,05	9,96	17,45	1,41	1,96	3,68	5,16	8,96
Outlet air temp	°C	14,50	15,40	16,90	18,20	21,50	15,50	16,40	17,60	18,70	22,10	16,10	17,80	19,10	19,90	22,60	16,30	17,40	18,60	19,50	22,60	14,70	15,50	16,90	18,30	21,60	16,90	18,50	20,10	21,00	23,40
water flow	m³/h	0,78	1,02	1,43	1,76	3,01	0,56	0,82	1,19	1,46	2,54	0,36	0,41	0,73	0,94	1,46	0,38	0,58	0,97	1,22	2,07	1,26	1,66	2,34	2,88	5,04	0,24	0,34	0,63	0,89	1,53
pressure drop	kPa	6,45	10,17	18,12	26,16	65,99	3,57	6,77	12,94	18,43	48,00	1,59	2,04	5,51	8,41	18,12	1,78	3,67	8,89	13,27	32,87	14,07	22,81	41,10	58,87	154,87	0,79	1,39	4,10	7,34	18,84
		Airflow 2800 m³/h (speed 1)																													
Cooling power	kW	3,68	4,86	6,75	8,48	14,72	2,62	3,81	5,58	6,93	12,43	2,33	2,69	4,15	5,28	8,14	2,11	2,79	4,56	5,72	10,11	3,55	4,69	6,48	8,17	14,39	1,28	1,89	2,98	4,17	7,33
Outlet air temp	°C	14,10	14,80	16,30	17,50	20,40	15,20	15,90	17,00	18,10	21,20	15,50	17,10	18,50	19,20	21,00	15,80	17,00	18,10	18,80	21,90	14,20	15,00	16,30							

Drip tray installation instructions

On the bottom of the EPP cast (red rectangle) it is necessary to make a drainage hole, to let the water run to the drip tray

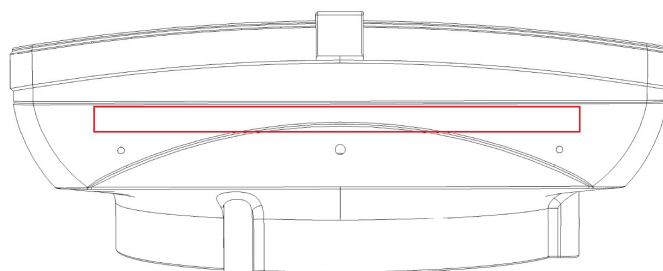

The drip tray is installed by screwing the set together with the factory mounting screw supplied with the HEATER CONDENS console. Side handles position and stiffen the tray connection. The tray is equipped with a connector with an external diameter of 13 mm

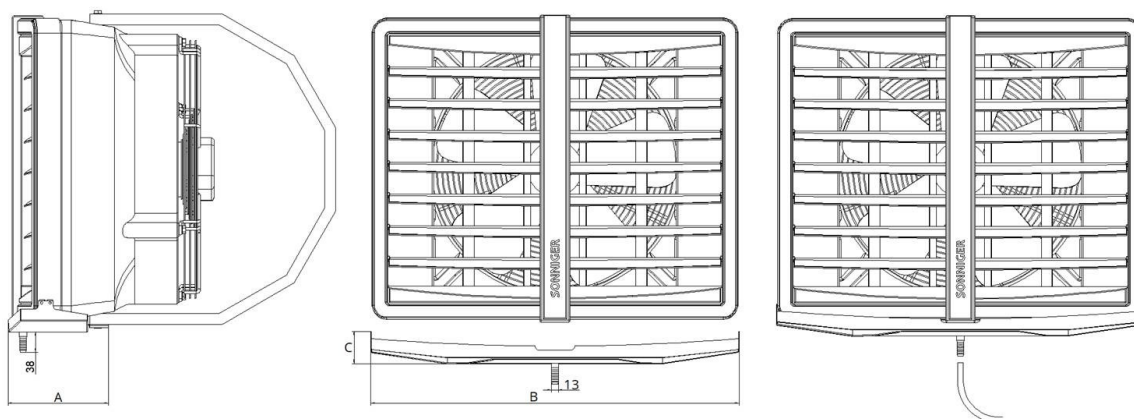

Dimension [mm]	Tray CR	Tray CR MAX
A	195	199
B	685	782
C	58	62

To ensure a more stable installation, the tray can be screwed to the heater casing using 4.5 x 40 wood screws. The screws are not included in the set.

